

Please read and save this Repair Parts Manual. Read this manual and the General Operating Instructions carefully before attempting to assemble, install, operate or maintain the product described. Protect yourself and others by observing all safety information. The Safety Instructions are contained in the General Operating Instructions. Failure to comply with the safety instructions accompanying this product could result in personal injury and/or property damage! Retain instructions for future reference.

1 1/2-Inch Solids-Handling Pump

Refer to form 1808-633-00 for General Operating and Safety Instructions.

Description

These centrifugal pumps are engine-driven, self-priming (to 20 ft. lift), portable units, shipped completely assembled and mounted. Pumps include a clog resistant impeller capable of handling solids as large as 3/8" diameter (up to 25% by volume). A built-in check valve assists in priming and a mechanical shaft seal prevents leakage. All seals are Buna N. Suction and discharge ports are 1 1/2" NPT female pipe thread. Handle liquids from 40° to 180° F (4° to 82° C). For use with nonflammable liquids compatible with pump component materials.

Specifications

Dimensions 22"L x 17 7/8"W x 19 3/8"H
 Engine 3 1/2 HP Briggs & Stratton
 Weight 77 lbs.
 Basic construction cast iron

Maintenance

▲ WARNING To prevent accidental starting always remove the spark plug, or disconnect and ground the spark plug wire before attempting to service or remove any component.

CLEANING

This unit has been designed with a removable volute enabling the pump to be cleaned or unclogged with ease. Remove casing and volute as described in steps 1 and 2 under MECHANICAL SEAL REPLACEMENT. Remove any debris found inside the unit, reassemble as described in steps 16 and 17 under MECHANICAL SEAL REPLACEMENT.

NOTE: Depending on application it may be necessary to remove suction and discharge hoses.

MECHANICAL SEAL REPLACEMENT

Refer to Figures 1 and 2.

IMPORTANT: Always replace the seal seat (Ref. No. 5), seal head (Ref. No. 6),

and the shaft sleeve (Ref. No. 7) to insure proper mating of mechanical seal components!

1. Unthread cap screws (Ref. No. 14) and remove casing (Ref. No. 12) and o-ring (Ref. No. 4) from the adapter (Ref. No. 3).
2. Unthread round head screws (Ref. No. 15) and remove volute (Ref. No. 10) from adapter.
3. Unscrew impeller (Ref. No. 9) from the engine shaft. Remove the impeller shim(s) (Ref. No. 8), shaft sleeve, and seal head from engine shaft.

NOTE: To keep the shaft from turning, remove the shroud from the engine and hold the flywheel in place.

4. Unthread hex flange screw (Ref. No. 2) and remove the adapter from the engine mounting face.
5. Push seal seat from the adapter recess with a screwdriver.
6. Clean the adapter recess before inserting a new seal seat.
7. Carefully wipe the ceramic surface of the new seal seat with a clean cloth.

8. Wet the outside of the rubber portion of the seal seat with a light coating of soapy water.
9. Press the new seal seat squarely into the cavity in the adapter. Use finger pressure only to avoid scratching the seal seat. (This is a lapped surface and must be handled very carefully.)
10. After the seal seat is in place, insure that it is clean and has not been marred.
11. Using a clean cloth, wipe the shaft and make certain that it is perfectly clean.
12. Secure the adapter on the engine mounting face.

▲ CAUTION Tighten hex flange screws **EVENLY** to avoid cocking rabbet on engine mounting face.

13. Apply a light coating of soapy water to the inside rubber portion of seal head and slide onto the shaft sleeve. Slip the shaft sleeve with seal head onto the engine shaft with the black carbon face toward the white ceramic seal seat.

▲ CAUTION Do not touch or wipe the face of the polished surface part of the seal head.

14. Replace any impeller shim(s) removed in disassembly.
15. Screw impeller back in place, tightening until it is against the shaft sleeve.

Performance Chart

| Model | GPH of Water at Total Head in Feet | | | | | | | | | Max** Head |
|-------|------------------------------------|------|------|------|------|------|------|------|-----|------------|
| | 10' | 20' | 30' | 40' | 50' | 60' | 70' | 80' | 90' | |
| 3161 | 6720 | 6420 | 6000 | 5460 | 4740 | 3700 | 2500 | 1200 | — | 87 ft. |

(**) Shut-off; to convert to psi, divide by 2.31.

For Repair Parts, contact dealer where pump was purchased.

Please provide following information:

- Model number
- Serial number (if any)
- Part description and number as shown in parts list

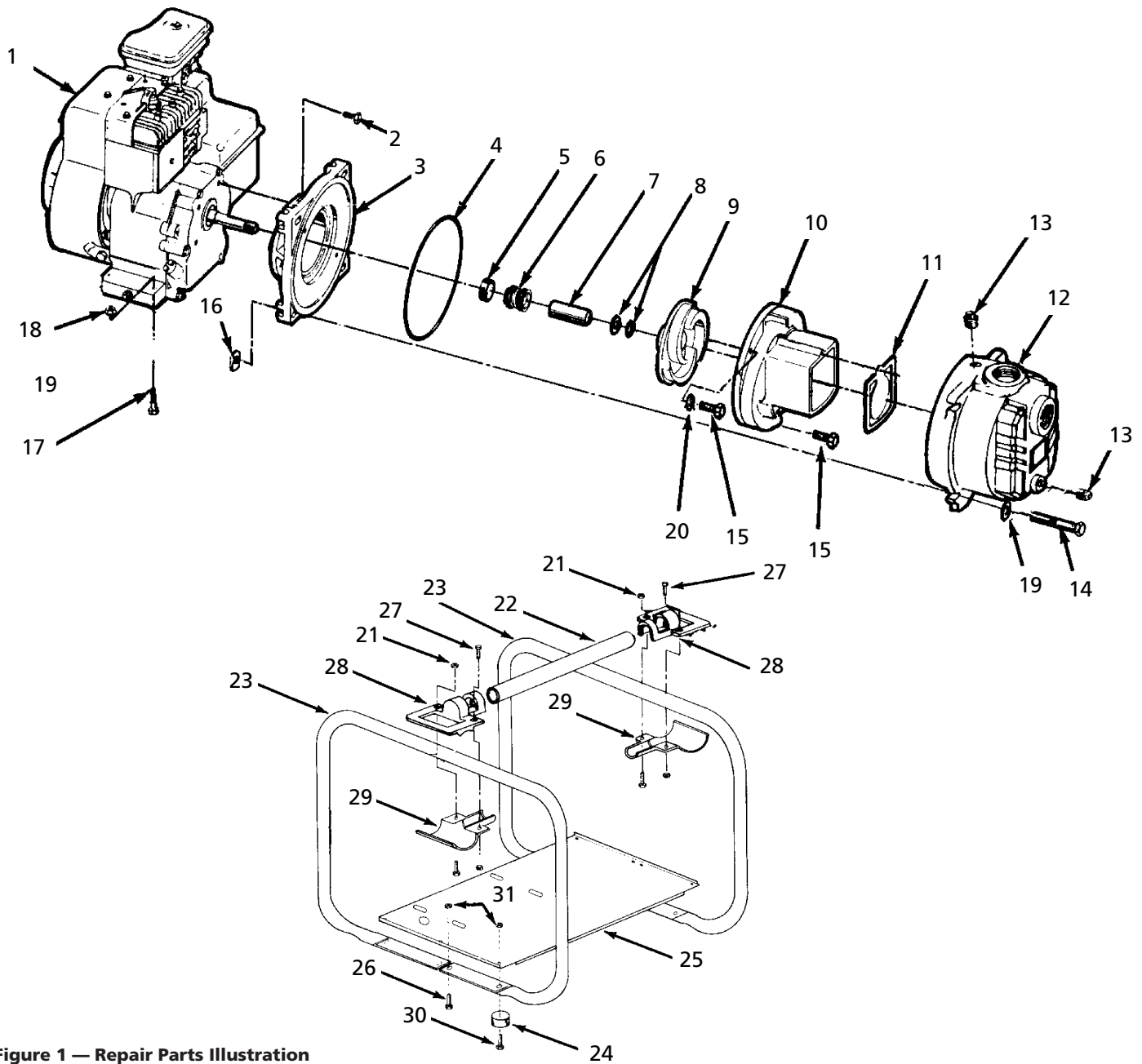

Figure 1 — Repair Parts Illustration

Model 3161-95

Repair Parts List

| Ref. No. | Description | Part Number | Qty. |
|----------|---|-------------|------|
| 1 | Engine | 1630-003-00 | 1 |
| 2 | 5/16"-24 UNF x 3/4" Hex cap screw | * | 4 |
| 3 | Adapter -cast iron | 1608-005-09 | 1 |
| 4 | O-ring -Buna N (standard) | 1610-000-00 | 1 |
| | -Viton (optional) | 1610-001-00 | |
| 5&6 | Seal assembly -Buna N (standard) | 1640-162-90 | 1 |
| | -Viton (optional) | 1640-162-91 | |
| 7 | Shaft sleeve | 1483-000-00 | 1 |
| 8 | Impeller shim pkg. (one each .010, .020, .030") | 1658-000-90 | 1 |
| 9 | Impeller | 1493-000-01 | 1 |
| 10 | Volute -cast iron | 1612-000-01 | 1 |
| 11 | Flapper valve -Buna N (standard) | 1609-002-00 | 1 |
| | -Viton (optional) | 1695-011-90 | |
| 12 | Casing -cast iron | 2111-001-01 | 1 |
| 13 | 1/2" NPT plug | * | 2 |
| 14 | 3/8"-16 UNC x 23/4" Hex head cap screw | * | 4 |
| 15 | #10-24 UNC x 7/8" Socket head screw SS | 1705-000-00 | 2 |
| 16 | 3/8"-16 UNC Hex nut | * | 4 |
| 17 | 5/16"-18 UNC x 1 1/2" Hex head cap screw | * | 4 |
| 18 | 5/16"-18 UNC Hex nut | * | 4 |
| 19 | 3/8" Flat washer | * | 4 |
| 20 | #10 Lockwasher SS | 1787-000-00 | 2 |
| 21 | 1/4"-20 UNC Hex nut | * | 4 |
| 22 | Frame brace | A433-100-00 | 1 |
| 23 | Outside rail | A433-101-00 | 2 |
| 24 | Rubber foot | 1508-000-00 | 4 |
| 25 | Frame base | 1668-000-00 | 1 |
| 26 | 1/4"-20 UNC x 1/2" Hex head cap screw | * | 4 |
| 27 | 1/4"-20 UNC x 3/4" Hex head cap screw | * | 4 |
| 28 | Upper frame clamp | 1696-098-00 | 4 |
| 29 | Lower frame clamp | 1696-097-00 | 4 |
| 30 | 1/4"-20 UNC x 3/4" Hex head cap screw | * | 4 |
| 31 | 1/4"-20 UNC Hex nut | * | 8 |
| Δ | 1 1/2" NPT Pipe nipple | 1696-044-00 | 2 |
| Δ | 1 1/2" NPT Suction strainer | 1679-001-00 | 1 |

(*) Standard hardware item, available locally.

(†) Available as set only.

(Δ) Not shown.

1½-Inch Solids-Handling Pumps

Maintenance (Continued)

16. Remount volute and position O-ring in place.

IMPORTANT: Always inspect O-ring. Replace when cracked or worn. Wet O-ring with soapy water for ease of assembly.

17. Remount casing.

SHIM ADJUSTMENT

1. When installing a replacement engine, adapter, impeller, shaft sleeve, volute or casing it may be necessary to vary the number of impeller shims (Ref. No. 8) that will be required. This is easily done by adding one shim more than was removed and reassembling the pump as described in MECHANICAL SEAL REPLACEMENT section.

NOTE: When adding or removing shims, it is best to proceed with a 0.010" increment each time. Remove spark plug wire from engine and ground. While tightening the unit together turn the shaft (by pulling on the recoil starter, etc.); feel for the shaft seizing. If shaft begins to seize before the fasteners are completely tight, disassemble the pump and remove one shim and repeat assembly.

2. Once having added one shim more than original, ensure that the volute (Ref. No. 10) and adapter (Ref. No. 3) are firmly fitted (check fasteners Ref. Nos. 2 & 15). When engine turns freely add shims until it does strike, then remove a 0.010" shim. This should allow the proper clearance.
3. Proper running clearance for the impeller should be as close as possible to volute without striking; maximum clearance is 1/32" (0.032").
4. Follow the above procedure until proper clearance is obtained. This will ensure maximum performance.

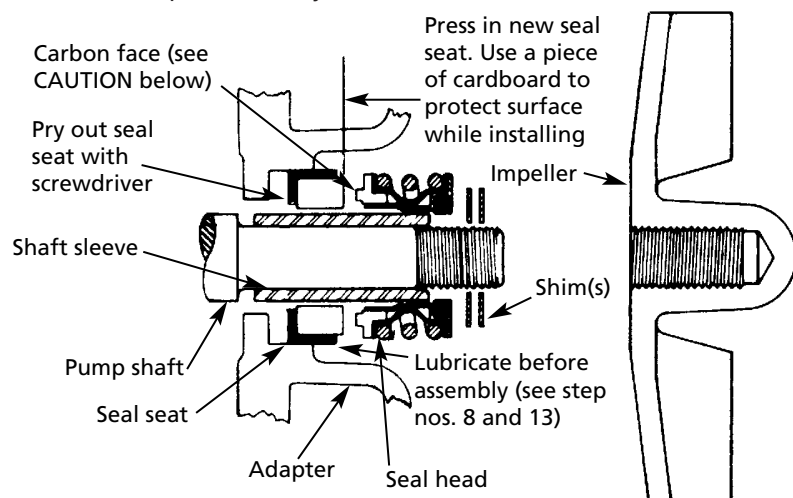

Figure 2 - Mechanical Seal Replacement