

2" Self-Priming Engine Driven AG/Dewatering Pumps



2" Dewatering Cast Iron Pump



2" Thermoplastic Pump

- **Cast Iron or Thermoplastic Construction**
- **Buna-N, EPDM or Viton® Mechanical Seal (Depending on Model)**
- **Optional Seals Available**
- **2" NPT Port Size**
- **Self-Priming up to 20 Ft.**
- **Semi-Open, Clog Resistant Impeller**
- **Solids Handling and Dirty Water Design**
- **Engine Options: Honda or CRX Gasoline**
- **Carry Handle Included**
- **Heavy Duty Steel Base Installed on Cast Iron Models**
- **Built-in Check Valve**

The AMT line of Engine Driven Dewatering pumps offers economy, durability, portability and performance all in one neat package. Ideal for dirty water dewatering, irrigation, spraying, washdown and agricultural applications. Pumps are designed to handle liquids with solids content or dissolved solids and debris. Cast iron pumps feature dual volute design that reduces radial load on engine. Built-in check valve enables constant self-priming to 20 feet. Pump construction materials available in cast iron or corrosive resistant polypropylene components featuring removeable/replaceable volute and impeller. Pumps are available with Honda or CRX Gasoline engines. Viton®, EPDM and Silicon Carbide mechanical seal options are available on specific models.

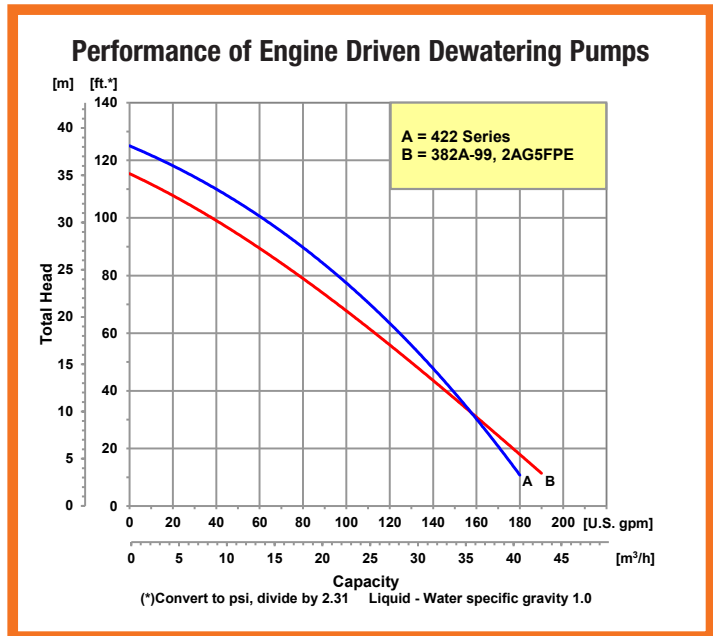

400 Spring Street • Royersford, PA 19468 USA

www.amtpump.com • 888-amt-pump (268-7867)

For use with nonflammable liquids compatible with pump component materials. Viton® and Teflon® are registered trademarks of E. I. DuPont.

2" Cast Iron AG/ Dewatering Pumps

Model	Curve	Port	Driver	Seal	Run Time (Hours)	Tank Size (Gal/Ltr.)	Ship Wt. (Lbs.)
4226-95	A	2" NPT	Honda GX160	Buna-N	2.0	0.82/3.1	82
4226-V5	A	2" NPT	Honda GX160	Viton	2.0	0.82/3.1	82
4229-95	A	2" NPT	CRX	Buna-N	2.0	0.87/3.3	85
4229-V5	A	2" NPT	CRX	Viton	2.0	0.87/3.3	85

Construction: Cast Iron

Maximum Solids Handling Capacity: 3/8" Diameter

Standard Features

- (2) NPT Pipe Nipples
- Buna-N or Viton® Mechanical Seal, Depending on Model
- Optional Silicon Carbide Mechanical Seals
- Built-in Check Valves
- Fiber Gasket Casing Seal
- Self-primes to 20 feet
- Semi-open, Clog Resistant Impeller
- Engine Shaft Protected with Stainless Steel Shaft Sleeve
- Maximum Temperature 180° F
- Maximum Working Pressure 75 PSI
- Delivers a Maximum of 180 GPM
- Dual Volute Design
- QSP – Quick Ship Pumps

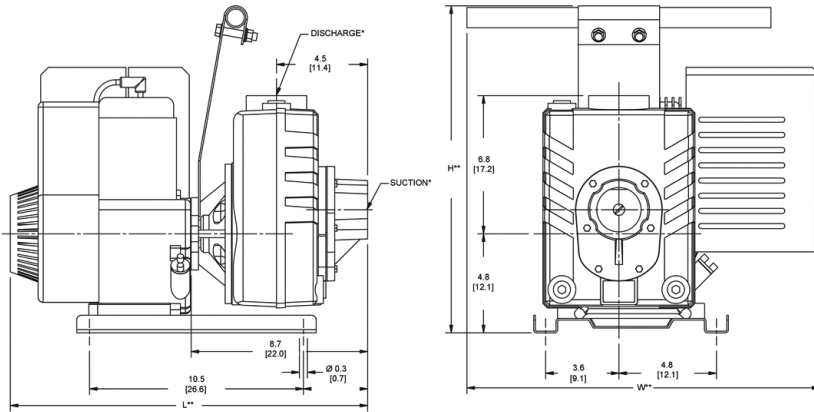

2" Thermoplastic AG/ Dewatering Pumps

Model	Curve	Port	Driver	Seal	Run Time (Hours)	Tank Size (Gal/Ltr.)	Ship Wt. (Lbs.)
382H-99	B	2" NPT	Honda GX160	Buna-N	1.5	0.47/1.7	45
2AG5FPE	B	2" NPT	CRX 210CC	EPDM	2.0	0.87/3.3	45

Construction: Polypropylene

Maximum Solids Handling Capacity: 7/16" Diameter

Standard Features

- (2) NPT Pipe Nipples
- Buna-N or EPDM Mechanical Seal and Check Valve
- O-ring Casing Seal
- Self-primes to 20 feet with Built-in Check Valve
- Replaceable Volute
- Maximum Temperature 130° F
- Maximum Working Pressure 60 PSI
- Delivers up to 48 PSI with a Maximum of 190 GPM
- QSP – Quick Ship Pumps

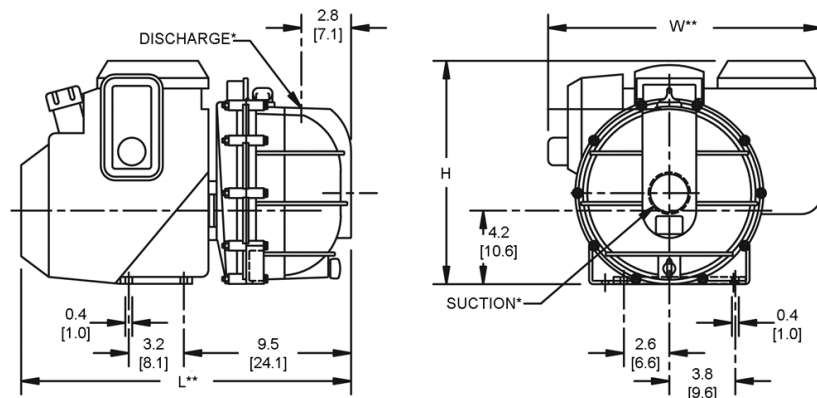

Model	HP Class	SUC*	DIS*	L**	W**	H**
382/2AG Series	5 HP	2"	2"	18.8 [47.7]	15.6 [39.6]	12.7 [32.2]
422 Series	5 HP	2"	2"	16.1 [40.8]	19.4 [49.2]	16.1 [40.8]

(♦) HP Class represents market category and is not intended to define actual horsepower.

(*) Standard NPT (Female) pipe thread.

(**) This dimension may vary due to engine manufacturer's specifications.

NOTE: Dimensions are in inches (centimeters) and have a tolerance of ± 1/8".