

Inline 3" Circulator Pumps

- **Silicon Bronze Construction**
- **EPDM/EPR Mechanical Seal and Casing O-Ring, Buna-N Option Available**
- **Silicon Bronze Impeller**
- **Mounting Flange Kit for 3" NPT Included**
- **Maximum Working Pressure 150 PSI**
- **Maximum Temperature 225° F (107° C)***
- **Maximum Flow 110 GPM**
- **Maximum Head 20 Ft. (9 PSI)**
- **Single Phase or Three Phase TEFC 56C Motor**



Model 5730-97
Bronze Circulator

AMT Inline Circulator Pumps are designed for continuous duty liquid transfer and chemical processing for industrial/commercial systems. Pumps are available in a variety of material configurations to meet your specifications. Pumps are powered by a 56C NEMA frame electric motor with 1/2" conduit connection. Pumps are interchangeable with other manufacturers, see cross reference on specification page.

*Maximum temperature applies to water only.

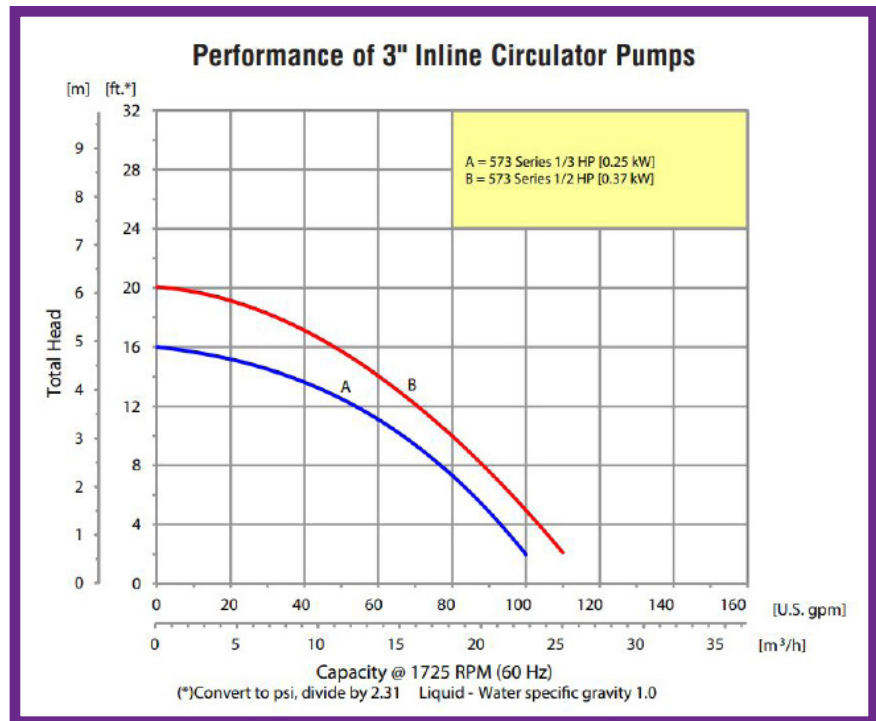

Pump Dimensional & Specification Data

Model ‡	Curve	HP	PH	ENC	Voltage @ 60 Hz	Full Load Amps	A**	B	C	L**	W	H	‡ Ship Wt. (Lbs.)
5735-97	A	1/3	1	TEFC	115/230	7/4	14.0 [35.5]	10.0 [25.4]	3.0 [7.6]	17.0 [43.2]	8.0 [20.3]	11.1 [28.2]	78
5736-97			3		230/460	2/1							75
5730-97	B	1/2	1	TEFC	115/230	9/5	14.0 [35.5]	10.0 [25.4]	3.0 [7.6]	17.0 [43.2]	8.0 [20.3]	11.1 [28.2]	84
5731-97			3		230/460	3/2							77

**This dimension may vary due to motor manufacturer's specifications

(+) 3-Phase models can also operate on 50 Hz. (This will change full load amps, service factor and RPM.)

NOTE: Dimensions are in inches (centimeters) and have a tolerance of $\pm 1/8"$

NOTE: Electric supply for ALL motors must be within $\pm 10\%$ of nameplate voltage rating (Ex. 230V $\pm 10\%$ = 207 to 253)

PUMPS ARE DESIGNED TO MOUNT HORIZONTALLY OR VERTICALLY

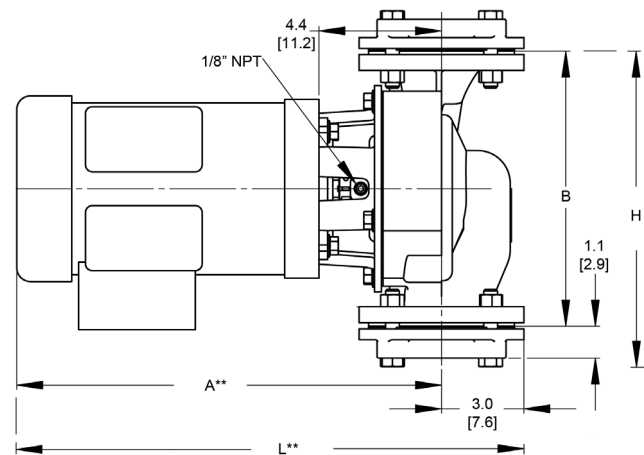
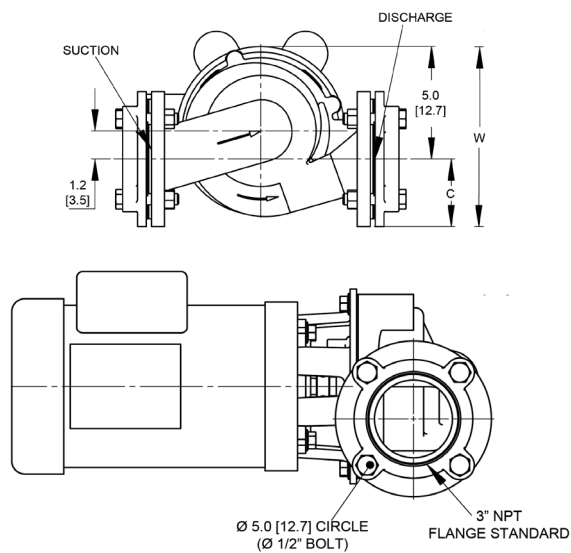

Manufacturer Cross Reference

Model Series	Flange to Flange Width	Bell & Gossett Series	Armstrong Series	TACO Series
5735/5736	10	LD3AB	S-45	122
5730/5731	10	HD3AB	S-46	131

Standard Features

- Mounting Flange Kit for 3" NPT, Which Includes (2) Flanges, (2) Gaskets, and Fasteners
- 4-Bolt Flange Allows 360° Mounting Rotation in 90° Increments
- 1/8" NPT Seal Wash/Vent Port
- EPDM/EPR Mechanical Seal and O-Rings
- Optional Buna-N Mechanical Seal and O-Ring Available
- Stainless Steel (300 Series) Stub Shaft
- High Efficiency Closed Impeller
- Standard NEMA 56C Motor Mounting Dimensions
- Available in either Single Phase or Three Phase TEFC 56C Motors
- Maximum Working Pressure 150 PSI
- QSP: Quick Ship Pump for Many Models